

# SHARP

OPTO-ANALOG DEVICES DIVISION  
ELECTRONIC COMPONENTS GROUP  
SHARP CORPORATION

## SPECIFICATION

DEVICE SPECIFICATION FOR

SOLID STATE RELAY

MODEL No.

S202T02

(Business dealing name : S202T02F)

Specified for \_\_\_\_\_

Enclosed please find copies of the Specifications which consists of 11 pages including cover.  
This specification sheets and attached sheets shall be both side copy.  
After confirmation of the contents, please be sure to send back  copies of the Specifications  
with approving signature on each.

CUSTOMER'S APPROVAL

DATE \_\_\_\_\_

BY \_\_\_\_\_

PRESENTED

DATE \_\_\_\_\_

BY H. I.

H. Imanaka,  
Department General Manager of  
Engineering Dept.,II  
Opto-Analog Devices Div.  
ELECOM Group  
SHARP CORPORATION

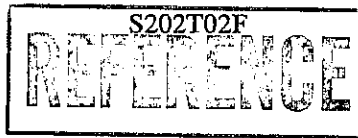

Product name : SOLID STATE RELAY

Model No. : S202T02

(Business dealing name : S202T02F)

1. These specification sheets include materials protected under copyright of Sharp Corporation ("Sharp"). Please do not reproduce or cause anyone to reproduce them without Sharp's consent.
2. When using this product, please observe the absolute maximum ratings and the instructions for use outlined in these specification sheets, as well as the precautions mentioned below. Sharp assumes no responsibility for any damage resulting from use of the product which does not comply with the absolute maximum ratings and the instructions included in these specification sheets, and the precautions mentioned below.

(Precautions)

- (1) This product is designed for use in the following application areas ;

[ · OA equipment · Audio visual equipment · Home appliances  
· Telecommunication equipment (Terminal) · Measuring equipment  
· Tooling machines · Computers ]

If the use of the product in the above application areas is for equipment listed in paragraphs (2) or (3), please be sure to observe the precautions given in those respective paragraphs.

- (2) Appropriate measures, such as fail-safe design and redundant design considering the safety design of the overall system and equipment, should be taken to ensure reliability and safety when this product is used for equipment which demands high reliability and safety in function and precision, such as ;

[ · Transportation control and safety equipment (aircraft, train, automobile etc.)  
· Traffic signals · Gas leakage sensor breakers · Rescue and security equipment  
· Other safety equipment ]

- (3) Please do not use this product for equipment which require extremely high reliability and safety in function and precision, such as ;

[ · Space equipment · Telecommunication equipment (for trunk lines)  
· Nuclear power control equipment · Medical equipment ]

- (4) Please contact and consult with a Sharp sales representative if there are any questions regarding interpretation of the above three paragraphs.

3. Please contact and consult with a Sharp sales representative for any questions about this product.

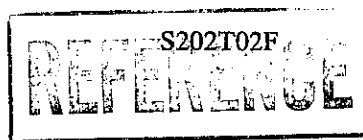

1. Application

This specification applies to the outline and characteristics of SIP type Solid State Relay (SSR), Model No. S202T02 (Apply line voltage 200V to 265V AC).

2. Outline Refer to the attached sheet, page 4.

3. Ratings and characteristics Refer to the attached sheet, page 5-6.

4. Reliability Refer to the attached sheet, page 7.

5. Outgoing inspection Refer to the attached sheet, page 8.

6. Supplement

6.1 The business dealing name used for this product when ordered or delivered shall be S202T02F.

6.2 This product is not designed against irradiation.

This product is assembled with electrical input and output.

This product incorporates non-coherent light emitting diode.

6.3 ODS materials

① This product shall not contain the following materials.

② Also, the following materials shall not be used in the production process for this product.

Materials for ODS : CFC<sub>s</sub>, Halon, Carbon tetrachloride, 1,1,1-Trichloroethane (Methylchloroform)

6.4 Specific brominated flame retardants such as the PBBO and PBB<sub>s</sub> are not used in this device at all.

6.5 Package specification Refer to the attached sheet, page 8-9

6.6 This Model is approved by UL and CSA

Approved Model No. : S202T02

UL file No. : E94758

CSA file No. : LR63705

7. Notes

7.1 Circuit design

(1) The LED used in the Solid State Relay generally decreases the light emission power by operation. In case of long operation time, please decide  $I_f$  value as 2 times or more of the Maximum value of the Minimum triggering current at circuit design with considering the decreases of the light emission power of the LED. (50%/5years)

(2) Input current ( $I_f$ ) at off-state shall be set 0.1mA or less.

(3) In case that L (Inductance) load such as motor etc. is used, please use this device after confirming whether this device operates normally in actual condition since there is a case that the zero-cross circuit works and the load does not turn on due to the phase difference of load current.

(4) Please make sure that surge absorption circuit and dv/dt control circuit are provided for protection of S202T02F.

In general, we recommend that both CR circuit and varistor be used in conjunction.

Watch for faulty operation that may be caused by leakage current that runs through the CR circuit.

(5) Some have a built-in rectifier such as diode, etc. as part of the electromagnetic counter or solenoid specified for use on AC.

If this is the case, check out properly the wave form of the load current.

If it is a rectangular wave as it may become, the SSR will not turn OFF.

# REFERENCE

## 7.2 Fixing of heat sink

- (1) Current value of the load shall be held within the range of derating curve.

Install an optional heat sink as required.

- (2) By using optional heat sink, if it is necessary to take isolation voltage between S202T02F and optional heat sink. Please use insulation sheet.
- (3) Optional heat sink shall be installed by screws-fastening torque 0.3 to 0.5N · m.

And, please conform to the below items in order to be sunk heat effectively to generating heat in this device.

- ① It shall be no unevenness on contacting surface among heat sink, insulation sheet and device.
- ② It shall be no burr and metal chip etc. on contacting surface among heat sink, insulation sheet and device.
- ③ It shall be spread equally silicone grease on contacting surface among heat sink, insulation sheet and device.  
Silicone grease shall be used such as :
  - ① No secular variation in operating temperature range.
  - ② Base oil does not separate and it does not stay in the device.
  - ③ If base oil permeate into the inside of the device, it does not effect any degradation, for example, due to the expansion of the coating material for chip.

For example, we recommend G-746; Shin-Etsu Chemical Co., Ltd. And SC-102; Dow Corning Toray Silicone Co., Ltd.

- (4) If it is necessary to employ screws with installation of optional heat sink, please solder after fixing screws.

- 7.3 If it is necessary to bend terminal pins, please bend them 3.8mm or more away from base of terminal pins to prevent mechanical stress between base of terminal pins and resin of mold.

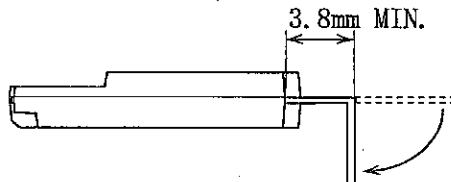

## 7.4 Cleaning

- (1) Solvent cleaning : Solvent temperature 45°C or less, Immersion for 3 min or less
- (2) Ultrasonic cleaning : The effect to device by ultrasonic cleaning differs by cleaning bath size, ultrasonic power output, cleaning time, PCB size or device mounting condition etc. Please test it in actual using condition and confirm that doesn't occur any defect before starting the ultrasonic cleaning.
- (3) Applicable solvent : Ethyl alcohol, Methyl alcohol, Isopropyl alcohol  
In case when the other solvent is used, there are cases that the packaging resin is eroded. Please use the other solvent after thorough confirmation is performed in actual using condition.

## 7.5 Precautions for Soldering

- (1) In case of flow soldering (Avoid immersing the resin part in the solder.)  
It is recommended that flow soldering should be carried out within 260°C and within 10s.  
(Pre-heating: 100 to 150°C, 30 to 80s) : Within 1 times
- (2) Other precautions  
Depend on equipment and soldering conditions (temperature, Using solder etc.), the effect to junction between PCB and lead pins of photocoupler is different. Please confirm that there is no problem on the actual use conditions

**S202T02F**  
**REFERENCE**

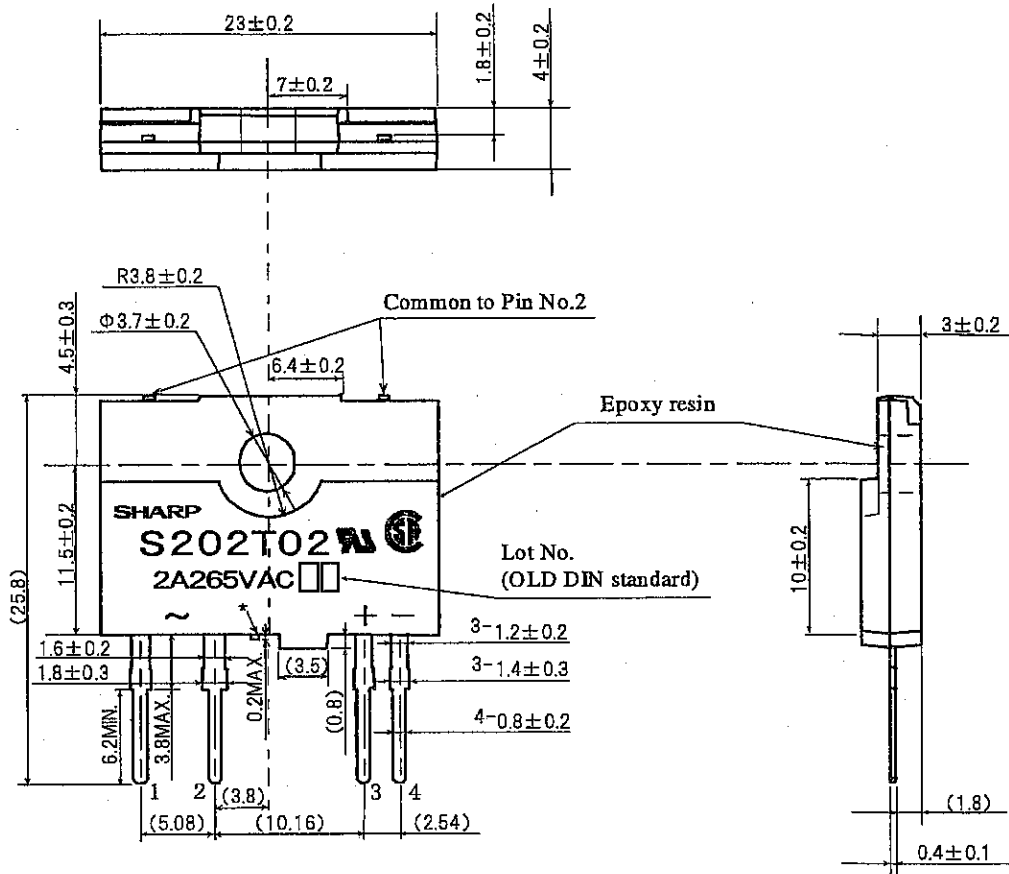

Product mass : Approx. 3.5g  
 Pin finish : SnCu plating (Cu : TYP. 2%)

Pin-Number and internal connection diagram

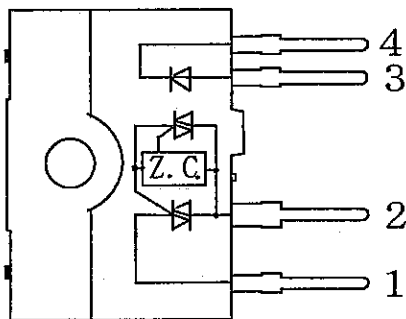

Pin Nos.	Connect
1	Output (Triac T1)
2	Output (Triac T2)
3	Input (+)
4	Input (-)

- 1) \* mark is not allowed external connection.
- 2) ( ): TYP.

UNIT : 1/1mm	
Name	S202T02 Outline Dimensions (Business dealing name : S202T02F)

3.1 Absolute maximum ratings

Ta=25°C

Parameter		Symbol	Rating	Unit	Conditions
Input	Forward current	$I_F$	50	mA	-
	Reverse voltage	$V_R$	6	V	-
Output	RMS on-state current	$I_T(\text{rms})$	2	A	Refer to the Fig.1
	Peak one cycle surge current	$I_{\text{surge}}$	20	A	60Hz sine wave, $T_j=25^\circ\text{C start}$
	Repetitive peak off-state voltage	$V_{\text{DRM}}$	600	V	-
	Non-repetitive peak off-state voltage	$V_{\text{DSM}}$	600	V	-
	Critical rate of rise of on-state current	$dI_T/dt$	40	A/ $\mu\text{s}$	-
	Operating frequency	f	45 to 65	Hz	-
Operating temperature		$T_{\text{opr}}$	-25 to +100	°C	-
Storage temperature		$T_{\text{stg}}$	-30 to +125	°C	-
Isolation voltage (*1)		$V_{\text{iso}}(\text{rms})$	3.0	kV	AC 60Hz, for 1min 40 to 60%RH
Soldering temperature		$T_{\text{sol}}$	260	°C	For 10 s

(\*1) Isolation voltage measuring method

- (1) Dielectric withstand tester, with zero-cross circuit shall be used.
- (2) The wave form of applied voltage shall be sine wave.
- (3) It shall be applied voltage between input and output. (Inputs and outputs shall be short-circuited respectively)

3.2 Electrical characteristics

Ta=25°C

Parameter		Symbol	MIN.	TYP.	MAX.	Unit	Conditions
Input	Forward voltage	$V_F$	-	1.2	1.4	V	$I_F=20\text{mA}$
	Reverse current	$I_R$	-	-	$10^{-4}$	A	$V_R=3\text{V}$
Output	Repetitive peak off-state current	$I_{\text{DRM}}$	-	-	$10^{-4}$	A	$V_D=V_{\text{DRM}}$
	On-state voltage	$V_T(\text{rms})$	-	-	1.7	V	$I_T(\text{rms})=2.0\text{A}$ , R load, $I_F=20\text{mA}$
	Holding current	$I_H$	-	-	25	mA	-
	Critical rate of rise of off-state voltage	$dv/dt$	30	-	-	V/ $\mu\text{s}$	$V_D=2/3V_{\text{DRM}}$
	Commutation critical rate of rise of off-state voltage	$(dv/dt)_c$	4	-	-	V/ $\mu\text{s}$	$T_j=125^\circ\text{C}$ , $V_D=2/3V_{\text{DRM}}$ $di_T/dt=-1.0\text{A/ms}$
Transfer characteristics	Minimum trigger current	$I_{\text{FT}}$	-	-	8	mA	$V_D=6\text{V}$ , $R_L=30\Omega$
	Zero-cross voltage	$V_{\text{ox}}$	-	-	35	V	$I_F=8\text{mA}$
	Isolation resistance	$R_{\text{iso}}$	$10^{10}$	-	-	$\Omega$	DC500V, 40 to 60%RH
	Turn on time	$t_{\text{ON}}$	-	-	10	ms	$V_D(\text{rms})=200\text{V}$ , AC50Hz,
	Turn off time	$t_{\text{OFF}}$	-	-	10	ms	$I_T(\text{rms})=2.0\text{A}$ , R load, $I_F=20\text{mA}$

3.3 Recommended operating conditions

Parameter		Symbol	Recommended operating conditions	Unit	Conditions
Input	Input signal current at on	$I_F(\text{on})$	16 to 24	mA	-
	Input signal current at off	$I_F(\text{off})$	0 to 0.1	mA	-
Output	Load supply voltage	$V_{\text{OUT}}(\text{rms})$	80 to 240	V	-
	Load supply current	$I_{\text{OUT}}(\text{rms})$	0.1 to 2.0	A	Refer to the Fig.1 ( $T_a < 40^\circ\text{C}$ )

(Fig.1) RMS on-state current derating curve

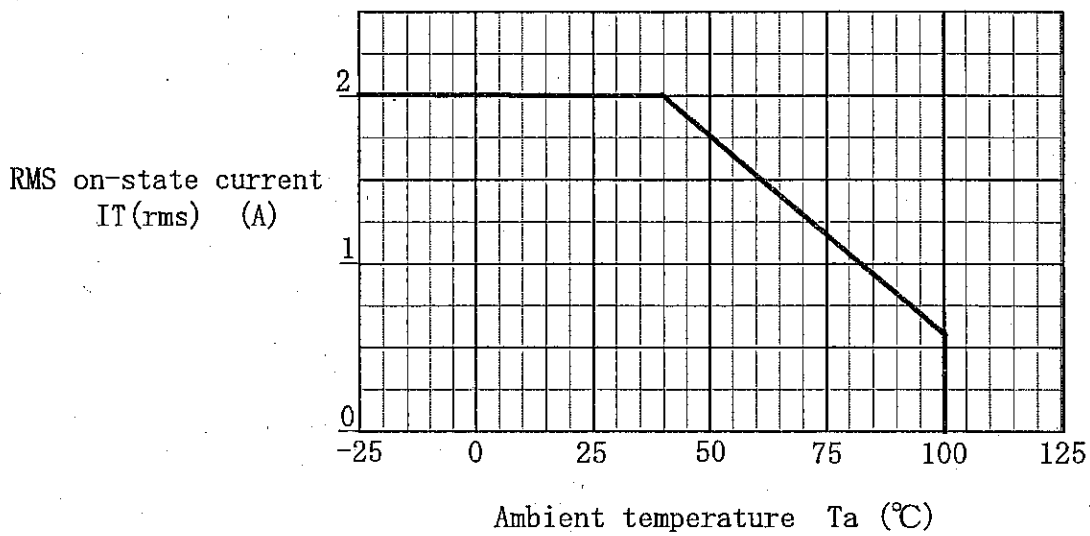

4. Reliability

The reliability of products shall satisfy items listed below.

Confidence level : 90%

LTPD : 10 or 20

Test Items	Test Conditions	Failure Judgement Criteria	Samples (n)
			Defective (C)
Temperature cycling	-30°C(30min)~+125°C(30min) 20cycles test	(1) $V_F > U \times 1.2$ (2) $I_R > U \times 2.0$ (3) $I_{DRM} > U \times 2.0$ (4) $V_T > U \times 1.2$ (5) $I_{FT} > U \times 1.2$	n=22, C=0
High temp. and high humidity storage	+60°C, 90%RH, 500h		n=22, C=0
High temp. storage	+125°C, 1000h		n=22, C=0
Low temp. storage	-30°C, 1000h		n=22, C=0
Intermittence operation	AC200V, $I_T$ (rms)=2.0A, $I_F$ =20mA 1min ON, 1min OFF $T_a=25 \pm 3^\circ\text{C}$ , 500h		n=22, C=0
Vibration	200m/s <sup>2</sup> , 100 to 2000Hz/ 4min 4 times/ X, Y, Z direction		n=11, C=0
Terminal strength (Bending)	The first bending test is to put back into the original shape after the terminal bent 90° by a 5N load. The second bending test is to do the same but opposite direction. These two tests shall be performed. *1		n=11, C=0
Terminal strength (Tension)	Weight : 10N, 30s/ terminal direction		n=11, C=0
Soldering heat	260°C, 10 s Up to 1.5mm from resin portion *2		n=11, C=0
Solderability	245 ± 3°C, 5s *2 solder:Sn/3.0Ag/0.5Cu flux:EC19S (TAMURA KAKEN CORPORATION)		Soldering area ≤ 95% of A portion

U : Max. specification values

\*1 Terminal bending direction is shown below.

\*2 Soldering area is shown below.

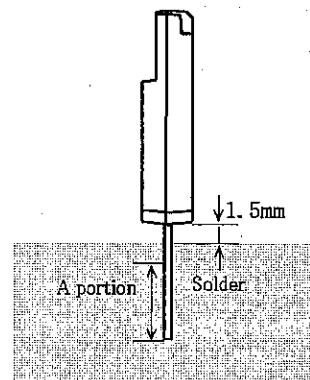
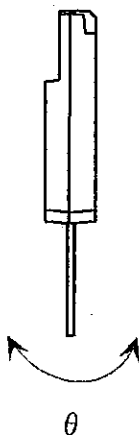

A portion : From the lower edge of fiber cut portion



5. Outgoing inspection

5.1 Inspection items

(1) Electrical characteristics

$$V_F \cdot I_R \cdot I_{DRM} \cdot V_T \cdot I_H \cdot I_{FT} \cdot R_{ISO} \cdot V_{iso}$$

(2) Appearance

5.2 Sampling method and Inspection level

A single sampling plan, normal inspection level II based on ISO 2859 is applied.

Defect	Inspection item	AQL (%)
Major defect	Electrical characteristics Unreadable marking	0.10
Major defect	Appearance defect except the above mentioned.	0.40

6.5 Package specification

6.5.1 Package materials

No.	Name	Materials	Purposes
1	Sleeve	HIPS	Products packaged
2	Stopper	Olefine-Elastomer	Products fixed
3	Packing case	Corrugated cardboard	Sleeve packaged
4	Kraft tape	Paper	Lid of packing case fixed
5	Label	Paper	Model No., (Business dealing name), quantity and inspection date specified.

6.5.2 Package method

- (1) MAX. 25pcs. of products shall be packaged in a sleeve and both of sleeve edges shall be fixed by stoppers.
- (2) MAX. 20 sleeves above shall be packaged in a packing case.
- (3) The label shall be put on the side of the packaging case.
- (4) Case shall be closed with the lid and enclosed with kraft tape.

6.5.3 Package outline dimensions

- (1) Sleeve outline dimensions Refer to the attached sheet, Page 9.
- (2) Packing case outline dimensions Refer to the attached sheet, Page 10.

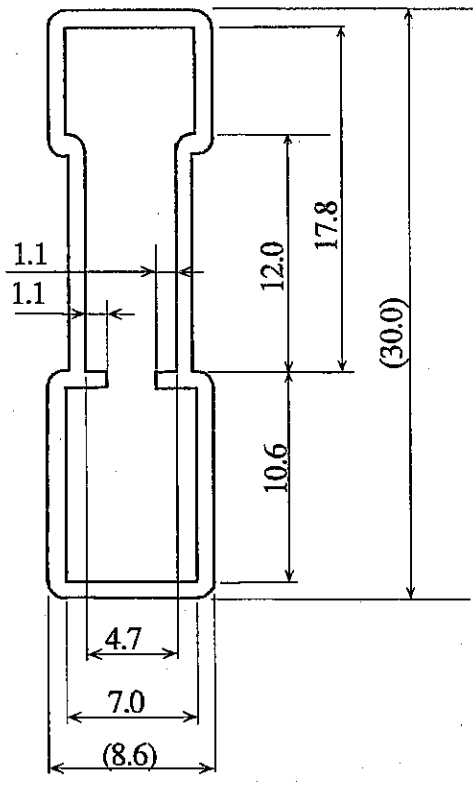
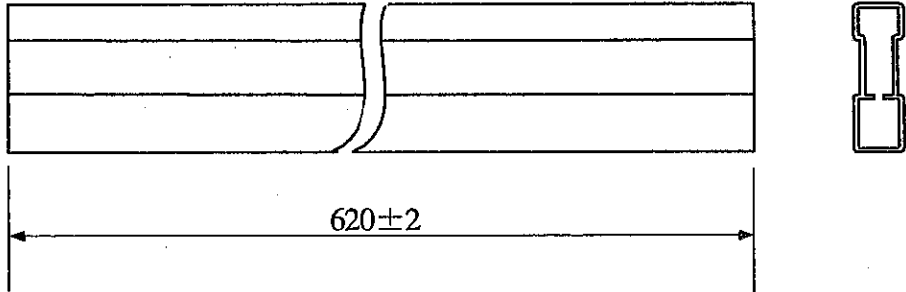

- Note 1) Thickness :  $0.8 \pm 0.2$
- 2) Unless otherwise specified tolerances shall be  $\pm 0.5$ mm.  
(However except for deformation due to the stopper in sleeve.)
- 3) ( ) : TYP.

Unit : 1= 1/1mm	
Name	Sleeve outline dimensions

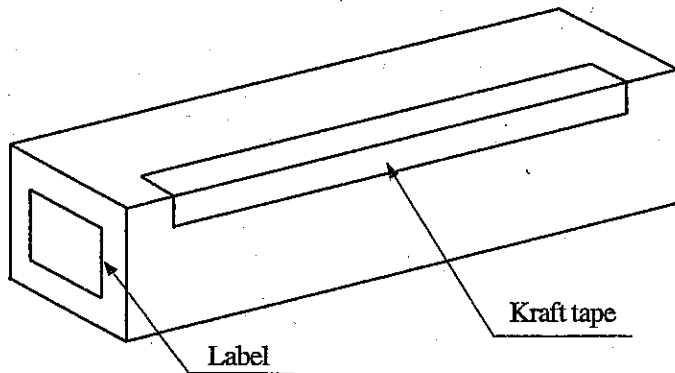
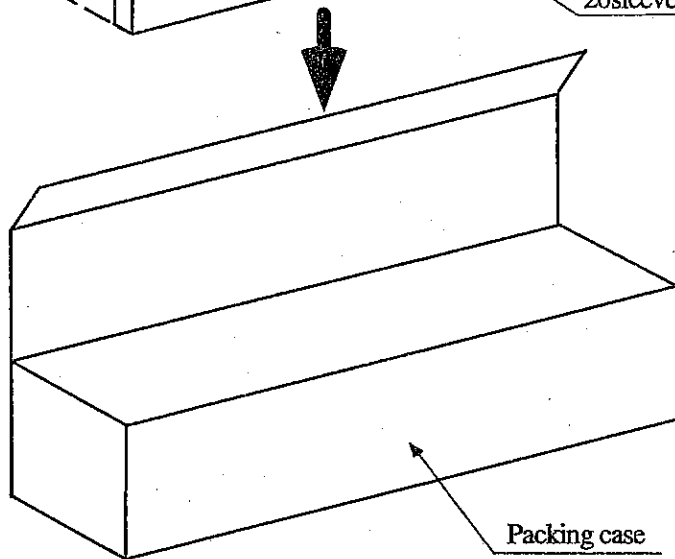
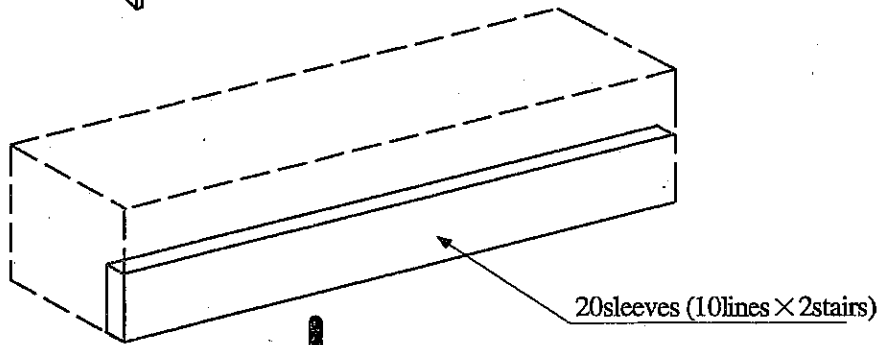
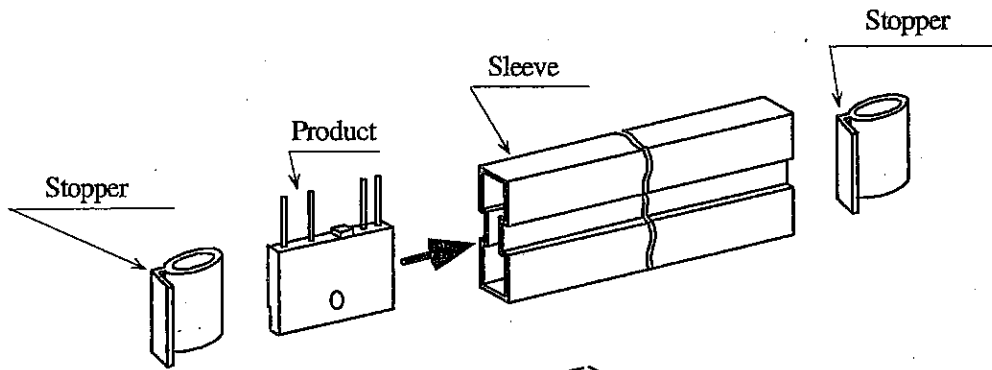

Name	Packing case outline dimensions
------	---------------------------------