

ISSUE : April 19, 2017

TO ; \_\_\_\_\_

## S P E C I F I C A T I O N S

Product Name      PHOTOTRIAC COUPLER

Model No.          3SD21

**【Business dealing name : PC3SD21\*TZBH】**

These specifications contain 15 pages including the cover and appendix.  
This specification sheets and attached sheets shall be both side copy.  
After confirmation of the contents, please be sure to send back      copy of the  
Specifications with approving signature on each.  
If you have any objections, please contact us before issuing purchasing order.

Accepted by:

By : \_\_\_\_\_  
Name :  
Title :  
Date :  
  
By : \_\_\_\_\_  
Name :  
Title :  
Date :

Sharp Corporation

By : T. Ichinose  
Name : T. Ichinose,  
Title : Division Manager,  
Development Division. V  
Semiconductor Business Unit  
Electronic Components and Devices BU  
Date : Apr. 19, 2017

Reviewed by :

By : T. Okuda  
Name : T. Okuda  
Title : Senior Manager  
Date : Apr. 19, 2017

Prepared by :

By : H. Shoji  
Name : H. Shoji  
Title : Supervisor  
Date : Apr. 19, 2017

1. These specification sheets include materials protected under copyright of Sharp Corporation ("Sharp"). Please handle with great care and do not reproduce or cause anyone to reproduce them without Sharp's consent.
2. When using this Sharp product, please observe the absolute maximum ratings, other conditions and instructions for use described in the specification sheets, as well as the precautions mentioned below.  
Sharp assumes no responsibility for any damages resulting from use of the product which does not comply with absolute maximum ratings, other conditions and instructions for use included in the specification sheets, and the precautions mentioned below.

(Precautions)

- (1) In making catalogue or instruction manual based on the specification sheets, please verify the validity of the catalogue or instruction manuals after assembling Sharp products in customer's products at the responsibility of customer.
- (2) This Sharp product is designed for use in the following application areas ;
  - Computers • OA equipment • Telecommunication equipment (Terminal) • Measuring equipment
  - Tooling machines • Audio visual equipment • Home appliancesIf the use of the Sharp product in the above application areas is for equipment listed in paragraphs (3) or (4), please be sure to observe the precautions given in those respective paragraphs.
- (3) Appropriate measures, such as fail-safe design and redundant design considering the safety design of the overall system and equipment, should be taken to ensure reliability and safety when Sharp product is used for equipment in responsibility of customer which demands high reliability and safety in function and precision, such as ;
  - Transportation control and safety equipment (aircraft, train, automobile etc.)
  - Traffic signals • Gas leakage sensor breakers • Rescue and security equipment
  - Other safety equipment
- (4) Sharp product is designed for consumer goods and controlled as consumer goods in production and quality. Please do not use this product for equipment which require extremely high reliability and safety in function and precision, such as ;
  - Space equipment • Telecommunication equipment (for trunk lines)
  - Nuclear power control equipment • Medical equipment
- (5) Please contact and consult with a Sharp sales representative if there are any question regarding interpretation of the above four paragraphs.

3. Disclaimer

The warranty period for Sharp product is one (1) year after shipment.  
During the period, if there are any products problem, Sharp will repair (if applicable), replace or refund.  
Except the above, both parties will discuss to cope with the problems.

The failed Sharp product after the above one (1) year period will be coped with by Sharp, provided that both parties shall discuss and determine on sharing responsibility based on the analysis results thereof subject to the above scope of warranty.

The warranty described herein is only for Sharp product itself which are purchased by or delivered to customer.  
Damages arising from Sharp product malfunction or failure shall be excepted.

Sharp will not be responsible for the Sharp product due to the malfunction or failures thereof which are caused by:

- (1) storage keep trouble during the inventory in the marketing channel.
- (2) intentional act, negligence or wrong/poor handling.
- (3) equipment which Sharp products are connected to or mounted in.
- (4) disassembling, reforming or changing Sharp products.
- (5) installation problem.
- (6) act of God or other disaster (natural disaster, fire, flood, etc.)
- (7) external factors (abnormal voltage, abnormal electromagnetic wave, fire, etc.)
- (8) special environment (factory, coastal areas, hot spring area, etc.)
- (9) phenomenon which cannot be foreseen based on the practical technologies at the time of shipment.
- (10) the factors not included in the product specification sheet.

4. Please contact and consult with a Sharp sales representative for any questions about Sharp product.

1. Application

This specification applies to the outline and characteristics of phototriac coupler Model No. 3SD21(Apply line voltage 200V AC).

2. Outline Refer to the attached sheet, page 5.

3. Ratings and characteristics Refer to the attached sheet, page 6, 7.

4. Reliability Refer to the attached sheet, page 8.

5. Outgoing inspection Refer to the attached sheet, page 9.

6. Supplement

6.1 Business dealing name ("○" mark indicates business dealing name of ordered product)

Product	Business dealing name	Remarks
	PC3SD21NTZBH	
	PC3SD21YTBH	Applied to products as an option (Attachment-1-1 to 1-3)

6.2 Isolation voltage shall be measured in the following method.

- (1) Short between pins 1 to 3 on the primary side and between pins 4 to 6 on the secondary side.
- (2) The dielectric withstanding tester with zero-cross circuit shall be used.
- (3) The wave form of applied voltage shall be a sine wave.  
(It is recommended that the isolation voltage be measured in insulation oil.)

6.3 Packing specifications Refer to the attached sheet, page 10, 11.

6.4 This Model is approved by UL. (Under preparation).

Approved Model No. : 3SD21

UL file No. : E64380

6.5 This Model is approved by CSA. (Under preparation).

Approved Model No. : 3SD21

CSA approved mark "  " shall be indicated on minimum unit package.

6.6 This product is not designed against irradiation.

This product is assembled with electrical input and output.

This product incorporates non-coherent light emitting diode.

6.7 ODS materials

This product shall not contain the following materials.

Also, the following materials shall not be used in the production process for this product.

Materials for ODS : CFCs, Halon, Carbon tetrachloride, 1.1.1-Trichloroethane (Methyl chloroform)

6.8 Specified brominated flame retardants

Specified brominated flame retardants (PBB and PBDE) are not used in this device at all

## 6.9 Compliance with each regulation

## (1) The RoHS directive(2011/65/EU)

This product complies with the RoHS directive(2011/65/EU) .

Object substances: mercury, lead, cadmium, hexavalent chromium, polybrominated biphenyls (PBB) and polybrominated diphenyl ethers (PBDE)

## (2) Content of six substances specified in Management Methods for Control of Pollution Caused by Electronic Information Products Regulation (Chinese : 电子信息产品污染控制管理办法).

Marking Styles for the Names and Contents of the Hazardous Substances

Category	Hazardous Substances					
	Lead (Pb)	Mercury (Hg)	Cadmium (Cd)	Hexavalent chromium (Cr <sup>6+</sup> )	Polybrominated biphenyls (PBB)	Polybrominated diphenyl ethers (PBDE)
Phototriac coupler	○	○	○	○	○	○

This table is prepared in accordance with the provisions of SJ/T 11364.

○ : Indicates that said hazardous substance contained in all of the homogeneous materials for this part is below the limit requirement of GB/T 26572

## 7. Notes

### 7.1 Ceaning

- (1) Solvent cleaning : Solvent temperature 45°C or less, Immersion for 3 min or less
- (2) Ultrasonic cleaning : The effect to device by ultrasonic cleaning differs by cleaning bath size, ultrasonic power output, cleaning time, PCB size or device mounting condition etc. Please test it in actual using condition and confirm that any defect doesn't occur before starting the ultrasonic cleaning.
- (3) Applicable solvent : Ethyl alcohol, Methyl alcohol, Isopropyl alcohol  
When the other solvent is used, there are cases that the packaging resin is eroded.  
Please use the other solvent after thorough confirmation is performed in actual using condition.

### 7.2 Circuit design

- (1) The LED used in the Phototriac coupler generally decreases the light emission power by operation. In case of long operation time, please decide  $I_F$  value so that  $I_F$  is more than 2 times of the Maximum value of the Minimum triggering current at circuit design with considering the decreases of the light emission power of the LED. (50% / 5years)
- (2) Input current ( $I_F$ ) at off state shall be set 0.1mA or less.
- (3) In case that L (Inductance) load such as motor etc. is used, please use this device after confirming whether this device operates normally in actual condition since there is a case that the zero-cross circuit works and the load does not turn on due to the phase difference of load current.
- (4) If the voltage exceeding the repetitive peak off-state voltage ( $V_{DRM}$ ) in the absolute maximum ratings is applied to the phototriac, it may cause not only faulty operation but breakdown. Make sure that the surge voltage exceeding  $V_{DRM}$  shall not be applied by using the varistor, CR.

### 7.3 In the case of flow soldering (Whole dipping is possible.)

- (1) It is recommended that flow solder should be at 270°C or less and within 10s or less.  
(Pre-heating : 100 to 150°C, 30 to 80s):Within 2 time
- (2) In the case of hand soldering  
What is done on the following condition is recommended.( 2 times or less)  
Soldering iron temperature : 400°C or less  
Time : 3s or less
- (3) Other precautions  
Depending on equipment and soldering conditions (temperature, Using solder etc.), the effect to the device and the PCB is different.  
Please confirm that there is no problem on the actual use conditions in advance.

### 7.4 Usage

For triggering medium and high power triac.  
(This model shall be used under the conditions on which power triac turns on.)

### (Notice)

**The contents described herein are subject to change without notice for improvement since this product is under development.**

2. Outline

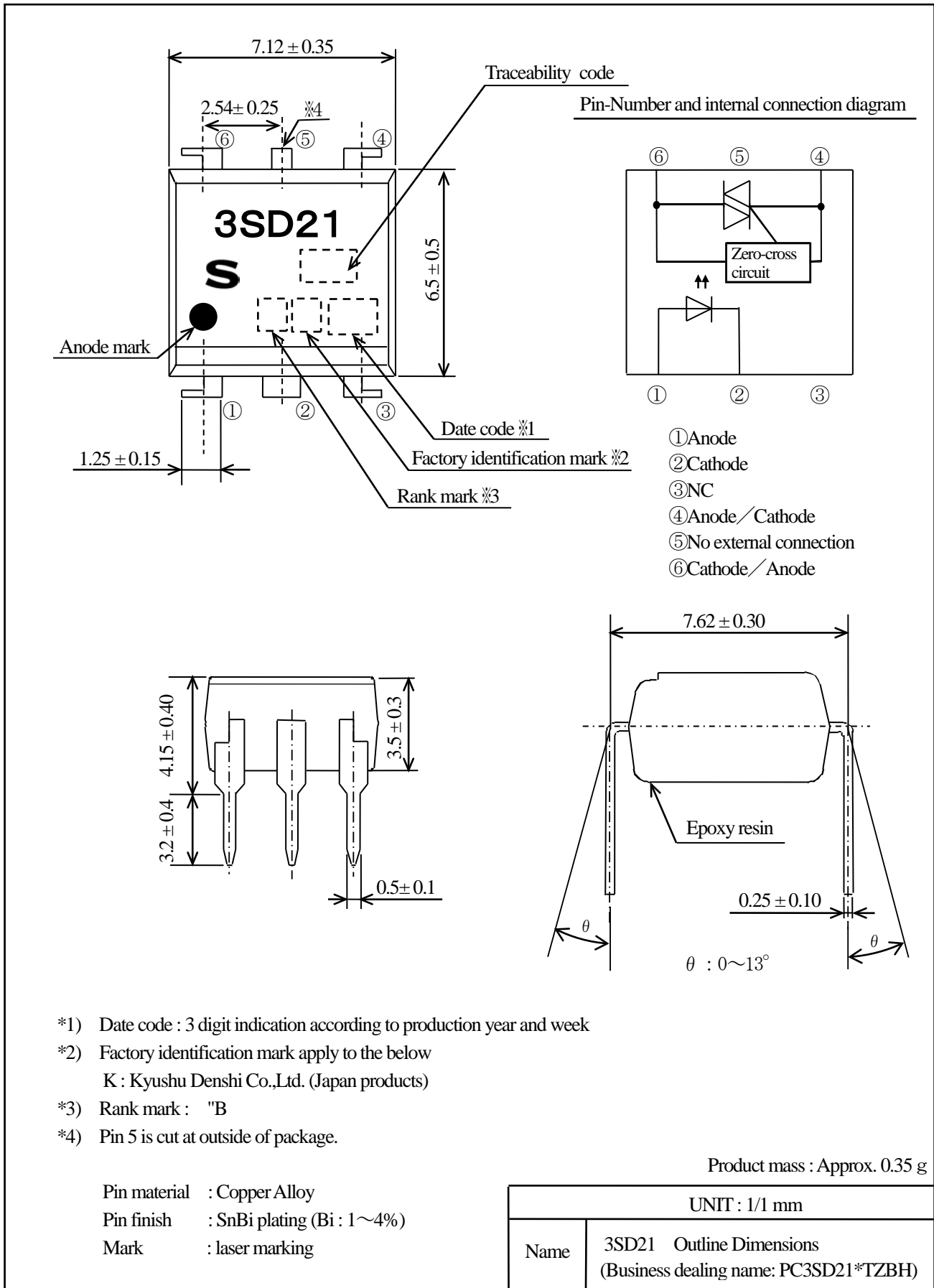

### 3. Ratings and characteristics

#### 3.1 Absolute maximum ratings

Ta=25°C

Parameter		Symbol	Rating	Unit
Input	Forward current *1	I <sub>F</sub>	50	mA
	Reverse voltage	V <sub>R</sub>	6	V
Output	RMS on-state current *1	I <sub>T(rms)</sub>	0.1	A
	Peak one cycle surge current	I <sub>surge</sub>	1.2(50Hz sine wave)	A
	Repetitive peak off-state voltage	V <sub>DRM</sub>	600	V
Isolation voltage *2		Viso(rms)	5	kV
Operating temperature		Topr	-30 to +100	°C
Storage temperature		Tstg	-55 to +125	°C
Soldering temperature		Tsol	270(10s)	°C

#### 3.2 Electro-optical characteristics

Ta=25°C

Parameter		Symbol	Conditions	MIN.	TYP.	MAX.	Unit
Input	Forward voltage	V <sub>F</sub>	I <sub>F</sub> =20mA	-	1.2	1.4	V
	Reverse current	I <sub>R</sub>	V <sub>R</sub> =3V	-	-	10 <sup>-5</sup>	A
Output	Repetitive peak off-state current	I <sub>DRM</sub>	V <sub>D</sub> =V <sub>DRM</sub>	-	-	10 <sup>-6</sup>	A
	On-state voltage	V <sub>T</sub>	I <sub>T</sub> =0.1A	-	-	2.5	V
	Holding current	I <sub>H</sub>	V <sub>D</sub> =4V	0.1	-	3.5	mA
	Critical rate of rise of off-state voltage	dv/dt	V <sub>D</sub> =1/√2 · V <sub>DRM</sub>	1000	2000	-	V/μs
	Zero-cross voltage	V <sub>OX</sub>	I <sub>F</sub> =15mA, R load	-	-	20	V
Transfer characteristics	Minimum trigger current	I <sub>FT</sub>	V <sub>D</sub> =4V, R <sub>L</sub> =100Ω	-	-	7	mA
	Isolation resistance	R <sub>ISO</sub>	DC500V 40 to 60%RH	5 × 10 <sup>10</sup>	10 <sup>11</sup>	-	Ω
	Turn on time	t <sub>ON</sub>	V <sub>D</sub> =4V, R <sub>L</sub> =100Ω, I <sub>F</sub> =20mA	-	-	50	μs

\*1 The derating factors of absolute maximum rating due to ambient temperature are shown in Fig.1, 2.

\*2 AC for 1min, 40 to 60%RH, f=60Hz

Fig.1 Forward current vs. Ambient temperature

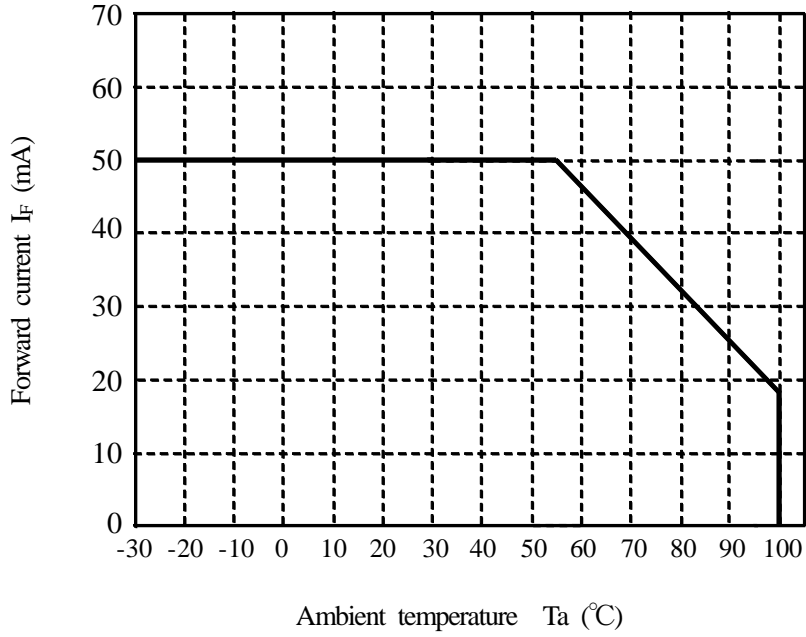
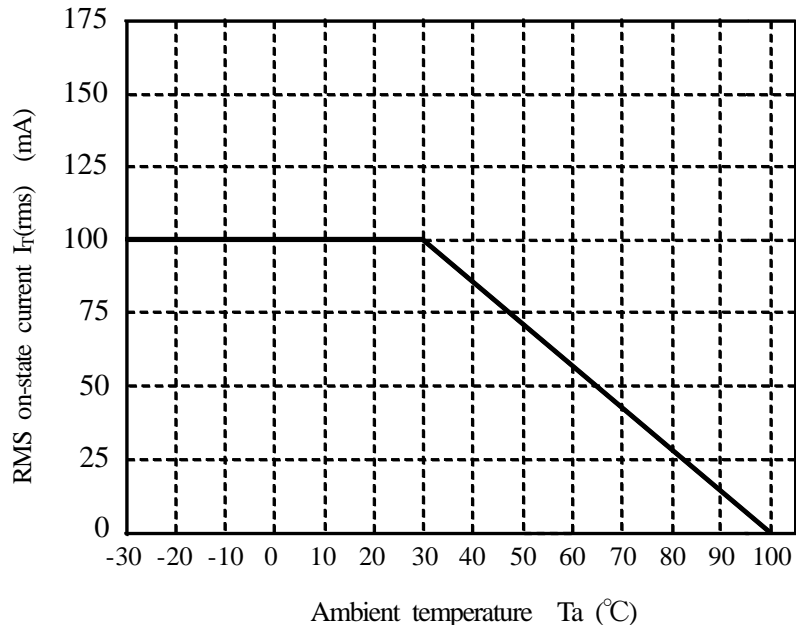

Fig.2 RMS on-state current vs. Ambient temperature





4. Reliability

The reliability of products shall satisfy items listed below.

Confidence level : 90%

LTPD : 10 or 20

Test Items	Condition *1	Failure Judgment Criteria	Samples (n)
			Defective (C)
Solderability	245±3°C, 5s	*2	n=11, C=0
Soldering heat *3	(Flow soldering) 270°C, 10 s	$V_F > U \times 1.2$ $V_T > U \times 1.2$ $I_{FT} > U \times 1.3$ $I_R > U \times 2.0$ $I_{DRM} > U \times 2.0$  U: Upper specification limit L: Lower specification limit	n=11, C=0
	(Soldering by hand) 400°C, 3 s		n=11, C=0
Terminal strength (Tension)	Weight: 5N 5s / each terminal		n=11, C=0
Terminal strength (Bending) *4	Weight: 2.5N 2 times / each terminal		n=11, C=0
Mechanical shock	15km/s <sup>2</sup> , 0.5ms 3 times / ±X, ±Y, ±Z direction		n=11, C=0
Variable frequency vibration	100 to 2000 to 100Hz / 4min, 200m/s <sup>2</sup> 4 times / X, Y, Z direction		n=11, C=0
Temperature cycling	1 cycle -55°C to +125°C (30 min) (30 min) 20 cycles test Without Load		n=22, C=0
High temp. and high Humidity storage	+85°C, 85%RH, 500h		n=22, C=0
High temp. storage	+125°C, 1000h		n=22, C=0
Low temp. storage	-55°C, 1000h		n=22, C=0
Operation life	I <sub>F</sub> =50mA, I <sub>T</sub> =100mA T <sub>a</sub> =25°C, 1000h	n=22, C=0	

\*1 Test method, conforms to EIAJ ED 4701.

\*2 The product whose not-soldered area is more than 5% for all of the dipped area and/or whose pinholes or voids are concentrated on one place shall be judged defect.

\*3 Dip into the position of 1.0mm from the resin part.

\*4 Terminal bending direction is shown below.

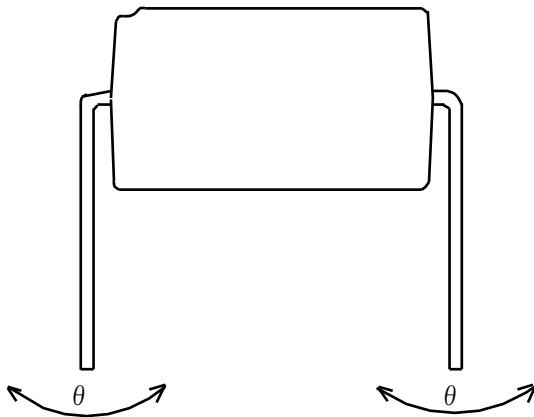

※ These test results are sampling examples from a specific lot for reference purpose only, and do not constitute any warranty or assurance in connection with the products

5. Outgoing inspection

5.1 Inspection items

- (1) Electrical characteristics  
 $V_F$ ,  $I_R$ ,  $I_{DRM}$ ,  $V_T$ ,  $I_{FT}$ ,  $R_{ISO}$ ,  $V_{ISO}$
- (2) Appearance

5.2 Sampling method and Inspection level

LTPD sampling inspection

Confidence level : 90%

Defect	Inspection item	LTPD (%)
Major defect	Electrical characteristics(faiure) Marking (Unreadable) Lead form (Deformation)	3
Minor defect	Appearance defect except the above mentioned.	50

6.2 Packing specification

6.2.1 Package materials

No.	Name	Materials	Purposes
①	Sleeve	HIPS or ABS with preventing static electricity	Products packaged
②	Stopper	Enhanced polymer	Products fixed
③	Inner bag	Polyethylene	Packaging bag for sleeve with product
④	Sealing tape	Cellophane	Lid of inner bag
⑤	Label	Paper	Model No.,(Business dealing name),Lot No., Quantity, Country of origin , Company name and Inspection date specified
⑥	Packing case	Paper	Inner bag packaged
⑦	Cushioning material	Polyethylene	Inner bag fixed
⑧	Sealing tape	Cellophane	Lid of packingcase
⑨	Label	Paper	Model No.,(Business dealing name),Lot No., Quantity, Country of origin , Company name and Inspection date specified

6.2.2 Package method

- (1) MAX. 60pcs. of products shall be packaged in a sleeve ① and both of sleeve edges shall be fixed by stoppers ②.
- (2) MAX. 25 sleeves (Product : 1500pcs.) above shall be packaged in inner case ③. and sealed by tape ④.
- (3) The label ⑤ shall be put on the top of the inner bag.
- (4) Max 2 bags(product : 3000pcs) above shall be packaged in packing case ⑥, and put a cushioning material ⑦ inside.
- (5) The label ⑨ shall be put on the side of the packing case.
- (6) Case shall be closed with the lid and enclosed with kraft tape ⑧.

6.2.3 Sleeve package ① outline dimensions

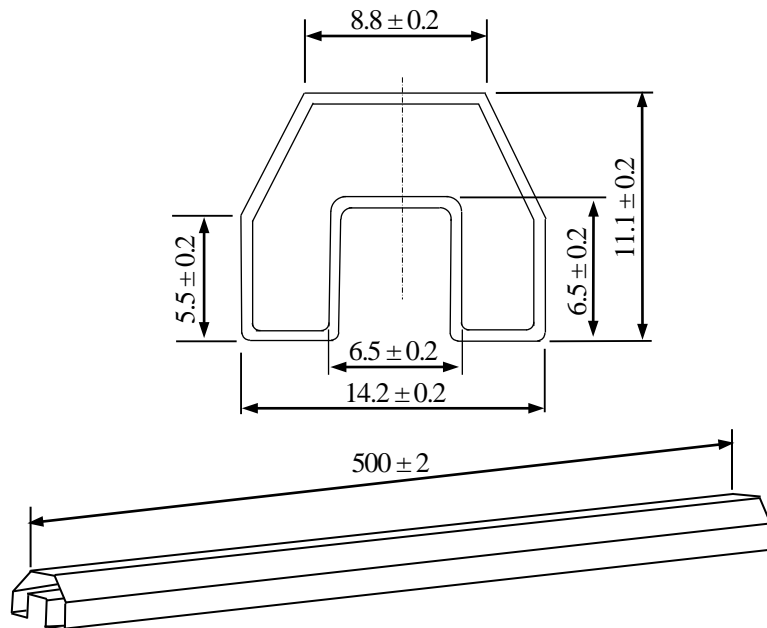

(Unit :mm)

- Note
- 1) Thickness :  $0.5 \pm 0.2$ mm
  - 2) Process with applying antistatic treatment.
  - 3) Unless otherwise specified tolerances shall be  $\pm 0.5$ mm.  
(However except for deformation due to the stopper in sleeve.)

# PCSD217BN REFERENCE

## 6.2.4 Packing outer case outline dimensions

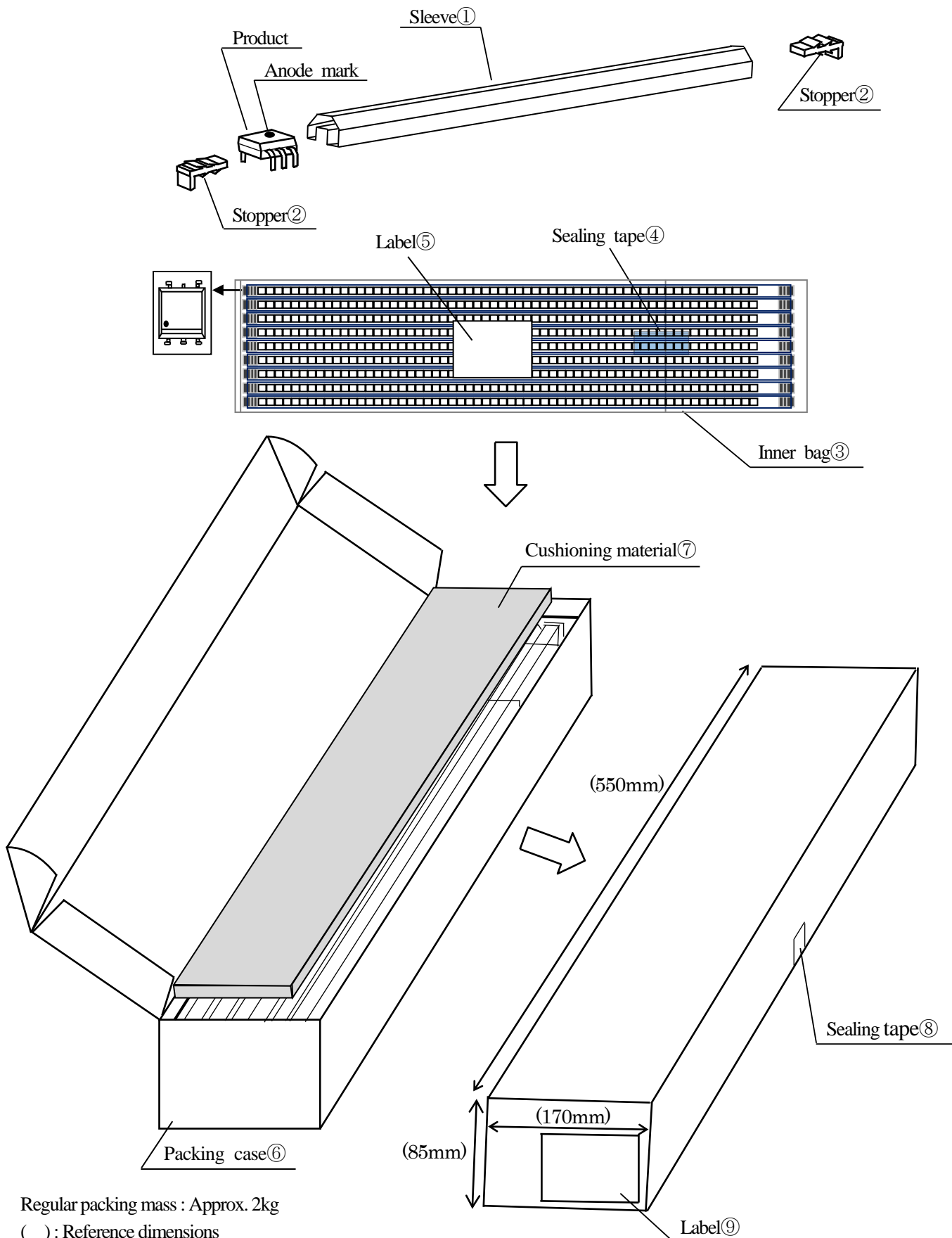

Regular packing mass : Approx. 2kg  
 ( ) : Reference dimensions

### Storage condition

Packaged products shall be stored at the temperature 5 to 30°C and the humidity 70%RH or less away from direct sunlight.

1. This specification shall be applied to phototriac coupler, Model No. 3SD21 series as an option.
2. Applicable Models (Business dealing name)  
PC3SD21YTZBH
3. The relevant models are the models Approved by VDE according to DIN EN 60747-5-5. (Under preparation).

Approved Model No. : 3SD21

VDE approved No. : Under preparation (According to the specification DIN EN 60747-5-5)

- Operating isolation voltage  $V_{IORM}$  : 890V (Peak)
- Transient voltage : 9000V (Peak)
- Pollution : 2
- Clearances distance (Between input and output) : 6.4mm (MIN.)
- Creep age distance (Between input and output) : 6.4mm (MIN.)
- Isolation thickness between input and output : 0.15mm (MIN.)
- Tracking-proof : CTI 175
- Safety limit values
  - Current (Isi) : 200mA (Diode side)
  - Power (Psi) : 400mW (phototriac coupler side)
  - Temperature (Tsi) : 150°C

In order to keep safety electric isolation of phototriac coupler,  
please set the protective circuit to keep within safety limit values  
when the actual application equipment troubled.

- Indication of VDE approval "  " is printed on minimum unit package.

4. Outline Refer to the attachment-1-2.

5. Isolation specification according to EN 60747-5-5

Parameter	Symbol	Condition	Rating	Unit	Remark	
Class of environmental test	-	-	40/100/21	-		
Pollution	-	-	2	-		
Maximum operating isolation voltage	$V_{IORM}$ (PEAK)	-	890	V	Refer to the Diagram 1 (Attachment-1-3) Refer to the Diagram 2 (Attachment-1-3)	
Partial discharge test voltage (Between input and output)	Diagram 1	$V_m$ $t_{nr}=10s, q_c<5pC$	1430	V		
	Diagram 2	$V_m$ (PEAK) $t_{stl}=1s, q_c<5pC$	1670	V		
Maximum over-voltage	$V_{ini.a}$ (PEAK)	$t_{ni}=60s$	9000	V		
Safety maximum ratings	1) Case temperature	Tsi	$I_f=0, P_c=0$	150	°C	Refer to the Fig. 3, 4 (Attachment-1-3)
	2) Input current	Isi	$P_c=0$	200	mA	
	3) Electric power (Output or Total power dissipation)	Psi	-	400	mW	
Isolation resistance (Test voltage between input and output ; DC500V)	$R_{ISO}$	$T_{amb}=T_{si}$	MIN.10 <sup>9</sup>	Ω		
		$T_{amb}=100°C$	MIN.10 <sup>11</sup>			
		$T_{amb}=25°C$	MIN.10 <sup>12</sup>			

Precautions in performing isolation test

- (1) Partial discharge test methods shall be the ones according to the specifications of EN 60747-5-5.
- (2) Please don't carry out isolation test ( $V_{iso}$ ) over  $V_{ini.a}$ .

This product deteriorates isolation characteristics by partial discharge due to applying high voltage (ex.  $V_{ini.a}$ ).

And there is possibility that partial discharge occurs in operating isolation voltage. ( $V_{IORM}$ ).

4. Outline

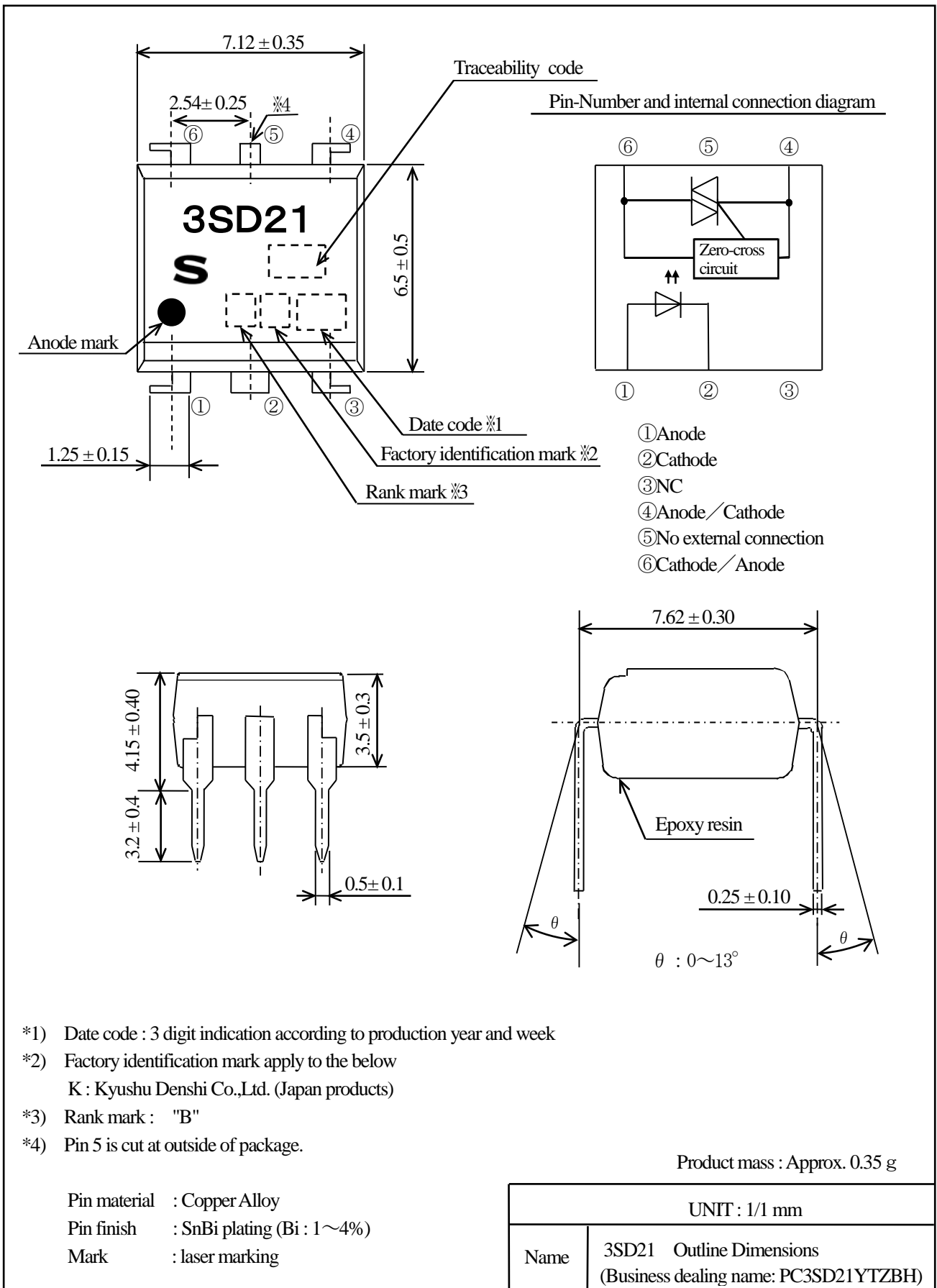

- \*1) Date code : 3 digit indication according to production year and week
- \*2) Factory identification mark apply to the below  
K : Kyushu Denshi Co.,Ltd. (Japan products)
- \*3) Rank mark : "B"
- \*4) Pin 5 is cut at outside of package.

Method of Diagram 1: Breakdown test (Apply to type test and sampling test)

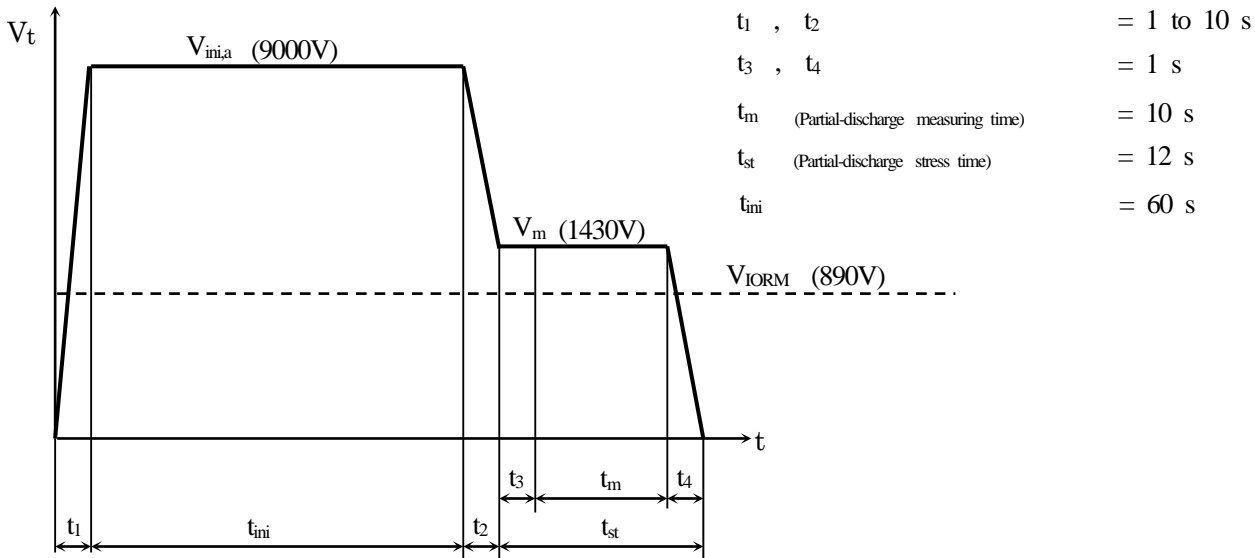

Method of Diagram 2: Non breakdown test (Apply to all device test)

