

**SHARP**

**REFERENCE**

SPEC No. ED-08G010  
ISSUE February 5, 2008

OPTO-ANALOG DEVICES DIVISION  
ELECTRONIC COMPONENTS GROUP  
SHARP CORPORATION

**SPECIFICATION**

DEVICE SPECIFICATION FOR

PHOTOINTERRUPTER

MODEL No.

GP1A173LCS2F

Specified for

---

Enclosed please find copies of the Specifications which consists of 13 pages including cover.  
After confirmation of the contents, please be sure to send back  copy of the Specifications  
with approving signature on each.

CUSTOMER'S APPROVAL

DATE

---

BY

---

PRESENTED

DATE

---

BY

*Y. O*

---

Y. Oda,  
Department General Manager of  
Engineering Dept., III  
Opto-Analog Devices Div.  
ELECOM Group  
SHARP CORPORATION

Product name : PHOTOINTERRUPTER

Model No. : GP1A173LCS2F

1. These specification sheets include materials protected under copyright of Sharp Corporation ("Sharp"). Please do not reproduce or cause anyone to reproduce them without Sharp's consent.
2. When using this product, please observe the absolute maximum ratings and the instructions for use outlined in these specification sheets, as well as the precautions mentioned below. Sharp assumes no responsibility for any damage resulting from use of the product which does not comply with the absolute maximum ratings and the instructions included in these specification sheets, and the precautions mentioned below.

(Precautions)

- (1) This product is designed for use in the following application areas ;

( • OA equipment   • Audio visual equipment   • Home appliances  
 • Telecommunication equipment (Terminal)   • Measuring equipment  
 • Tooling machines   • Computers

If the use of the product in the above application areas is for equipment listed in paragraphs (2) or (3), please be sure to observe the precautions given in those respective paragraphs.

- (2) Appropriate measures, such as fail-safe design and redundant design considering the safety design of the overall system and equipment, should be taken to ensure reliability and safety when this product is used for equipment which demands high reliability and safety in function and precision, such as ;

( • Transportation control and safety equipment (aircraft, train, automobile etc.)  
 • Traffic signals   • Gas leakage sensor breakers   • Rescue and security equipment  
 • Other safety equipment

- (3) Please do not use this product for equipment which require extremely high reliability and safety in function and precision, such as ;

( • Space equipment   • Telecommunication equipment (for trunk lines)  
 • Nuclear power control equipment   • Medical equipment

- (4) Please contact and consult with a Sharp sales representative if there are any questions regarding interpretation of the above three paragraphs.

3. Please contact and consult with a Sharp sales representative for any questions about this product.

# GP1A173LCS2F REFERENCE

1. Application

This specification applies to the outline and characteristics of transmissive type photointerrupter with connector, Model No. GP1A173LCS2F.

2. Outline

2.1 Outline : Refer to the attached drawing No. CY14233i02.

Coupling and contact to CT connector by Tyco Electronics AMP K.K. (2mm pitch)

2.2 Recommended Installation Hole drawing : Refer to the attached drawing No. CY14234i06.

3. Ratings and characteristics

Refer to the attached sheet, Page 6, 7.

4. Reliability

Refer to the attached sheet, Page 8.

5. Outgoing inspection

Refer to the attached sheet, Page 9.

6. Supplements

6.1 Parts

Refer to the attached sheet, Page 10.

6.2 Package drawing

Refer to the attached sheet, Page 11 or 12.

6.3 ODS materials

This product shall not contain the following materials.

Also, the following materials shall not be used in the production process for this product.

Materials for ODS : CFCs, Halon, Carbon tetrachloride, 1.1.1-Trichloroethane (Methyl chloroform)

6.4 Specified brominated flame retardants

Specified brominated flame retardants (PBB and PBDE) are not used in this device at all.

6.5 Country of origin : Philippine

6.6 Product mass : Approx. 1.0g

6.7 Compliance with each regulation

6.7.1 The RoHS directive(2002/95/EC)

This product complies with the RoHS directive(2002/95/EC) .

Object substances: mercury, lead, cadmium, hexavalent chromium, polybrominated biphenyls (PBB) and polybrominated diphenyl ethers (PBDE)

6.7.2 Content of six substances specified in Management Methods for Control of Pollution Caused by Electronic Information Products Regulation (Chinese : 电子信息产品污染控制管理办法).

Category	Toxic and hazardous substances					
	Lead (Pb)	Mercury (Hg)	Cadmium (Cd)	Hexavalent chromium (Cr <sup>6+</sup> )	Polybrominated biphenyls (PBB)	Polybrominated diphenyl ethers (PBDE)
Photointerrupter	✓	✓	✓	✓	✓	✓

✓ : indicates that the content of the toxic and hazardous substance in all the homogeneous materials of the part is below the concentration limit requirement as described in SJ/T 11363-2006 standard .

# REFERENCE

## 7. Notes

### 7.1 Truth Table (In case of external addition pull-up resistance to Vout terminal)

Light beam	Output
Interrupted	High
Uninterrupted	Low

### 7.2 Power supply line

In order to stabilize power supply line, connect a by-pass capacitor of More than  $0.01 \mu\text{F}$  between Vcc and GND near the device.

### 7.3 Opaque board

Opaque board shall be installed at place 4mm or more from the top of elements.  
(Example)

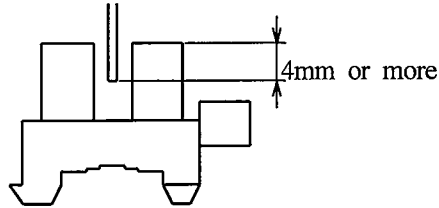

### 7.4 Cleaning

Please don't carry out immersion cleaning or ultrasonic cleaning to avoid keeping solvent inside case of this device.

### 7.5 Washing material

Dust and stain shall clean by air blow, or shall clean by soft cloth soaked in washing materials.

And washing material to clean shall be used the below materials only.

Ethyl alcohol, Methyl alcohol, Isopropyl alcohol

### 7.6 Connector connection

For the electrical connection to the connector terminal, please certainly use the connector specified in this specifications.

Please avoid the connection by the soldering or welding which may damage the main body of the device, and also avoid the contact by the clip and so on which may cause the malfunction by the contact failure.

### 7.7 Put-in and pull-out of connector

The connection other than to the correct connection direction, forcing-into, and the pulling-out diagonally (if being not put-in and pulled-out straight) may deform or break the connector terminal and/or housing, which may cause the unusable state of the device.

# REFERENCE

2.1 Outline (Drawing No.CY14233i02)

Scale : 2/1 Unit : 1/1mm

- Note) 1. Unspecified tolerance shall be followed the list below.  
 2. Dimensions in parenthesis are shown for reference.  
 3. Coupling and contact : MT receptacle connector (173977-3 and 179228-3) by Tyco Electronics AMP K.K.

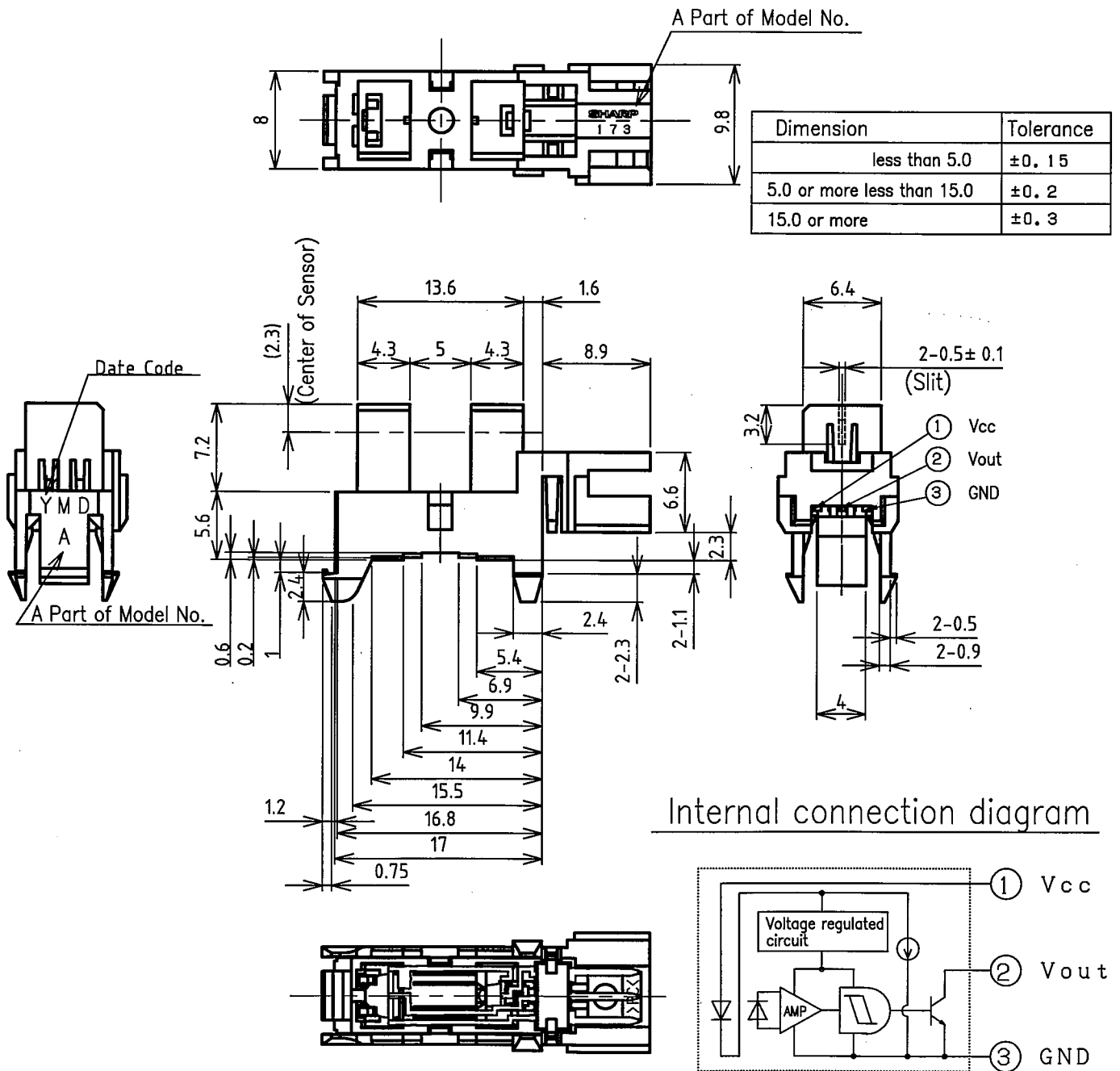

# REFERENCE

2-2 Recommended Installation Hole drawing  
(Drawing No. CY14234i06)

Scale : 2/1

Unit : 1/1mm

- \*1 We recommend to fix GP1A173LCS2F at punching side on the fixing plate (metal plate).
- \*2 Please decide the final dimensions at your side after confirmation by the actual applications, Because mounting efficiency and mounted stabilization are dependent on mounting plate corner-R and punched state.
- \*3 Tolerance shall be  $\pm 0.1\text{mm}$

Normal mounting type

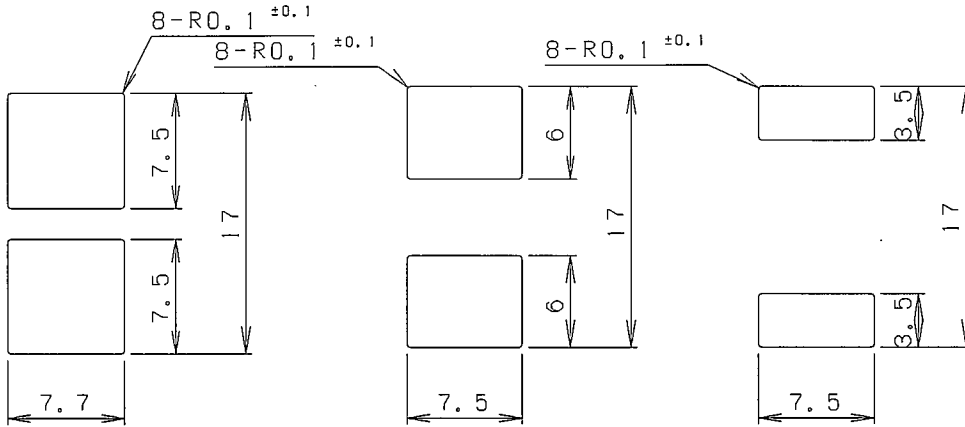

Thickness of plate for 1.6mm

Thickness of plate for 1.2mm

Thickness of plate for 1.0mm

Irregular mounting protection type

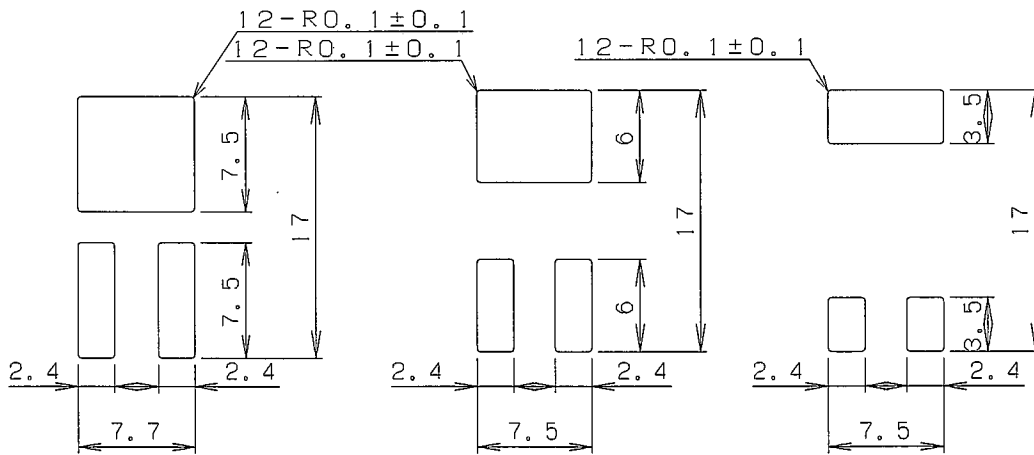

Thickness of plate for 1.6mm

Thickness of plate for 1.2mm

Thickness of plate for 1.0mm

## 3. Ratings and characteristics

## 3.1 Absolute maximum ratings

Ta=25°C

Parameter	Symbol	Rating	Unit	Remark
Supply voltage	V <sub>cc</sub>	-0.5 to +7	V	
Output voltage	V <sub>out</sub>	-0.5 to +7	V	Output transistor between collector and emitter
Output current	I <sub>OL</sub>	8	mA	Output transistor collector current *1
Operating temperature	Topr	-30 to +95	°C	The connector should be plugged in/out at normal temperature.
Storage temperature	Tstg	-40 to +100	°C	

\*1 Fig.1 shows output current vs. ambient temperature.

## 3.2 Electro-optical characteristics

V<sub>cc</sub>=5V, Ta=25°C

Parameter	Symbol	Rating	Unit	Conditions	
Current dissipation	I <sub>CCL</sub>	16.5 MAX.	mA	Light beam uninterrupted	
Low level output voltage	V <sub>OL</sub>	0.35 MAX	V	Light beam uninterrupted I <sub>OL</sub> =4mA	
Current dissipation	I <sub>CCH</sub>	16.5 MAX	mA	Light beam interrupted	
High level output voltage	V <sub>OH</sub>	(V <sub>cc</sub> ×0.9) MIN	V	Light beam interrupted R <sub>L</sub> =47kΩ	
Operating voltage	V <sub>cc</sub>	4.5 to 5.5	V		
Response characteristics	Min. interrupted time	t <sub>H</sub>	166 MIN	μs	R <sub>L</sub> =4.7kΩ
	Min. uninterrupted time	t <sub>L</sub>	166 MIN	μs	

3.3 Detection position characteristics (Ta=25°C, V<sub>cc</sub>=5V, R<sub>L</sub>=47kΩ)

Horizontal detecting position characteristics

(d = 2.35 ± 0.3mm)

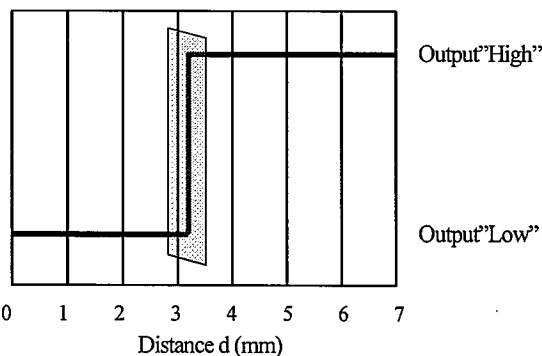

Vertical detecting position characteristics

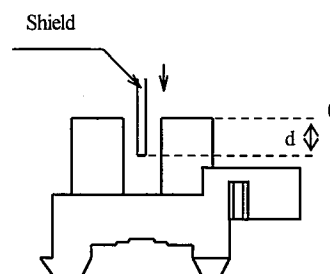
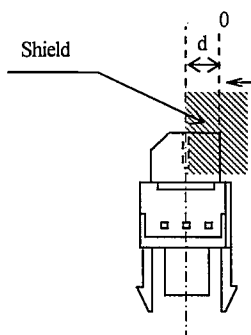
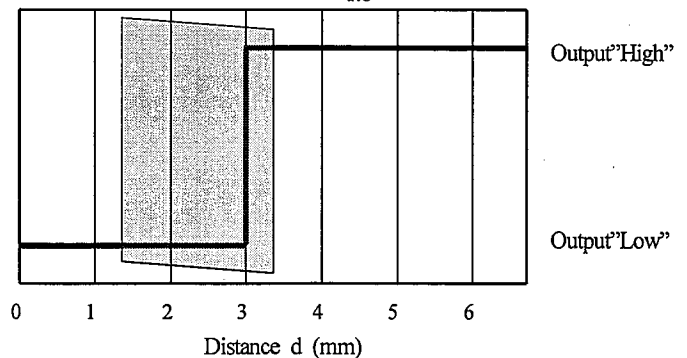
(d = 3.0<sup>+0.3</sup><sub>-1.8</sub> mm)

**REFERENCE**

Fig.1 Output current vs. ambient temperature

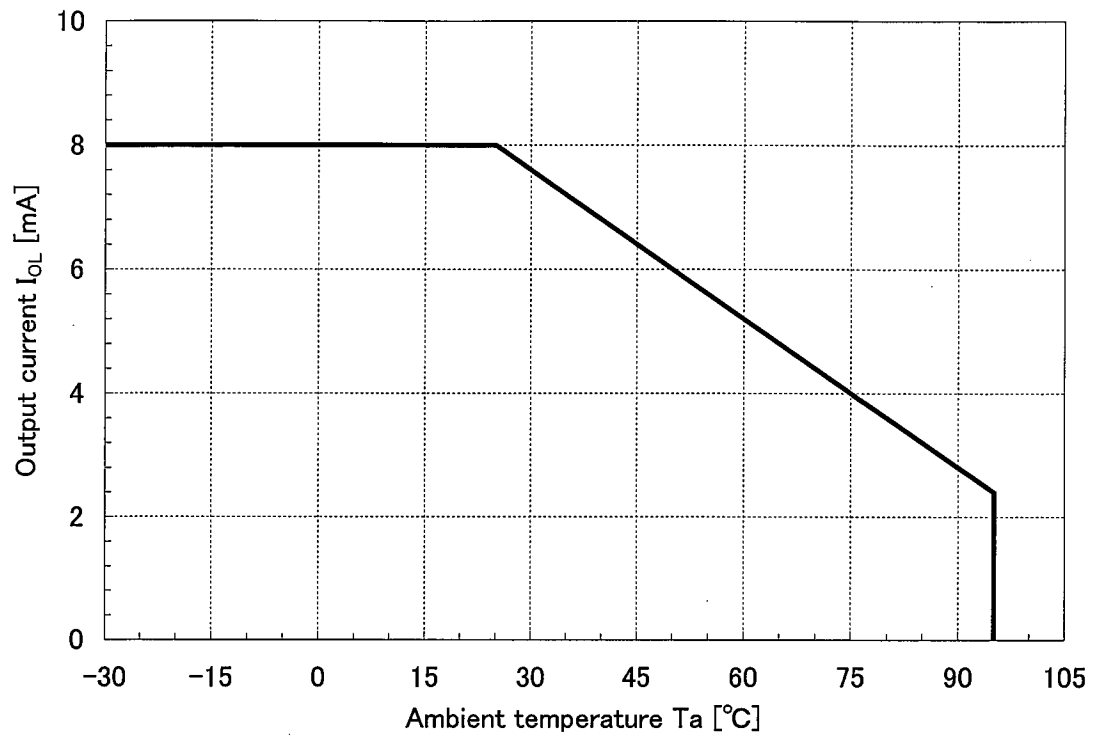



# REFERENCE

## 4. Reliability

The reliability of products shall satisfy items listed below.

Confidence level : 90%

LTPD : 10 or 20

Test item	Test conditions	Failure Judgement Criteria	Samples (n)
			Defective(C)
Temperature cycling	1 cycle -40°C to +100°C (30min) (30min) 100 cycles test	$I_{CCL} \geq U \times 1.2$	n=22, C=0
High temp. and high humidity storage	+40°C, 90%RH, 240h	$I_{CCH} \geq U \times 1.2$	n=22, C=0
High temp. storage	+100°C, 240h, Without connector	$V_{OL} \geq U \times 1.2$	n=22, C=0
Low temp. storage	-40°C, 240h	$V_{OH} \leq L \times 0.8$	n=22, C=0
Operation life	$V_{CC}=5V$ , $T_a=25 \pm 3^\circ C$ , 1000h		n=22, C=0
Mechanical shock	1000m/s <sup>2</sup> , 3times/ X, Y, Z direction		n=11, C=0
Variable vibration frequency	Overall amplitude ; 1.5mm Frequency range 10 to 55 to 10 Hz/1 min 2h/ X, Y, Z direction	U : Upper specification limit L : Lower specification limit	n=11, C=0
Connector strength I	Pull connector housing horizontally to connector terminal pin direction by 20N weight for 5 s (1 time)	Abnormal electro-optical characteristics	n=11, C=0
Connector strength II	Push connector housing perpendicular to connector terminal pin direction by 10N weight for 5 s (1 time)		n=11, C=0

# REFERENCE

## 5. Outgoing inspection

	Item	Conditions	Instrument	Judge Criteria	AQL
1	Appearance	No defects that may conflict with product specifications, including crack, split, chip scratch, burr and blur, No bent connector pin and loosened pin	Visual inspection	Any of the specified defects at left is not acceptable	1.0%
2	Electro-optical characteristics	Specified in 3.2 ( $I_{CCL}$ , $V_{OL}$ , $I_{CCH}$ , $V_{OH}$ , $V_{CC}$ )	Dedicated tester	Specimen that does not satisfied the requirements specified at left is not acceptable	0.4%

A single sampling plan, normal inspection level II based on ISO 2859 shall be adopted.

# REFERENCE

## 6. Supplements

### 6.1 Parts

This product uses the below parts.

#### 6.1.1 Light detector (Quantity : 1)

(Using a silicon photodiode as light detecting portion, and a bipolar IC as signal processing circuit.)

Type	Maximum sensitivity wavelength (nm)	Sensitivity wavelength (nm)	Response time ( $\mu$ s)
Photodiode	900	400 to 1200	10

#### 6.1.2 Light emitter (Quantity : 1)

Type	Material	Maximum light emitting wavelength (nm)	I/O Frequency (MHz)
Infrared light emitting diode (non-coherent)	GaAs	950	0.3

#### 6.1.3 Material

Case	Lead flame
Black polycarbonate resin (UL 94V-2)	Copper Alloy (With plating)

#### 6.1.4 Others

This product shall not be radiation flux proof.

The laser oscillator is not equipped on this product.

The terminals are covered with Tin Plating (more than 99.99%).

## 6.2 Package drawing

### Package A

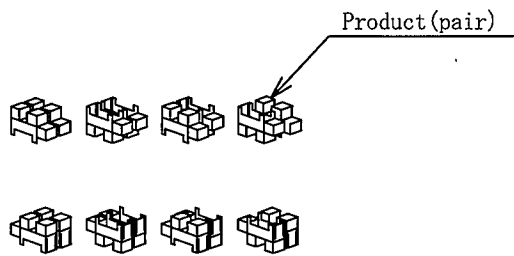

&lt;Fig 1&gt;

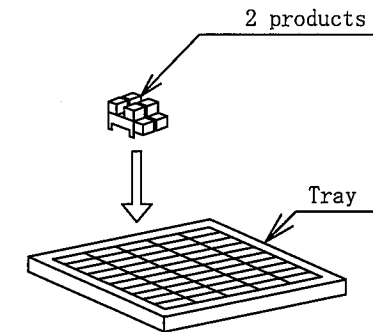

&lt;Fig 2&gt;

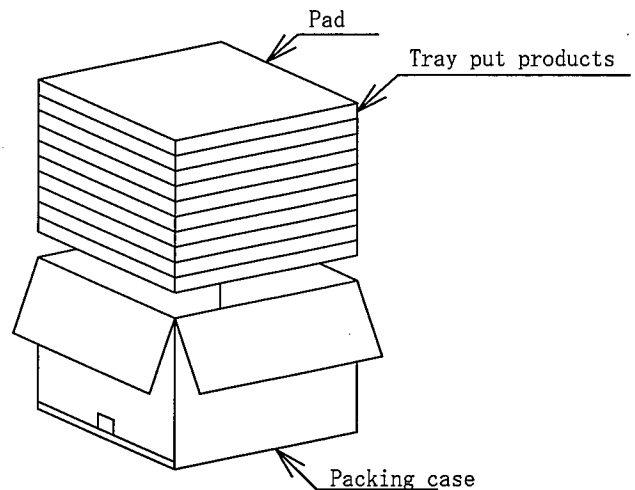

&lt;Fig 3&gt;

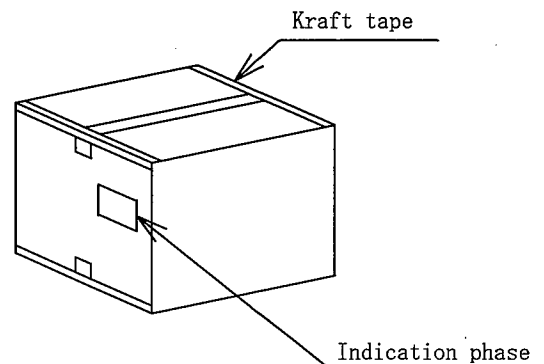

&lt;Fig 4&gt;

No	Name	Quantity
1	Packing case	1/1000
2	Pad	11/1000
3	Tray	1/100
4	Kraft tape	-

### Packing method

- 1 2 products are put in 1 pocket.  
The longer direction of the product is arranged in the arbitrary direction. <Fig.1>
- 2 100 products are put in the tray. <Fig.2>  
The pads are attached at the top and the bottom of the trays and also inserted between the trays. <Fig.3>
- 3 Seal packing case with kraft tape, and stamp  
Model No., quantity, date in Indication phase. <Fig.4>  
(1000pcs./ packing case)  
(Approximately 2.65kg/ packing mass)

# REFERENCE

## Package B

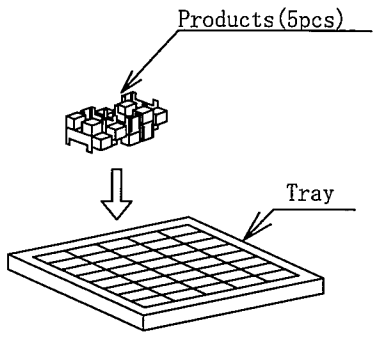

<Fig 1>

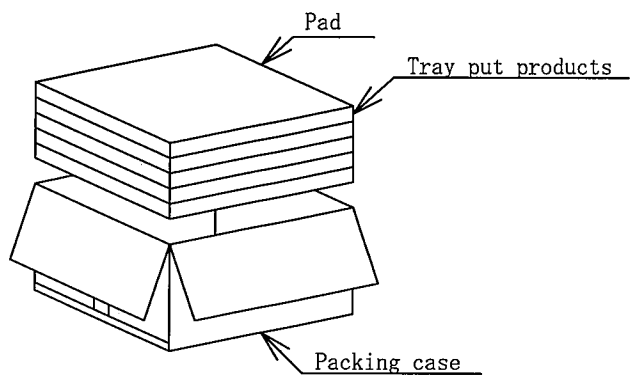

<Fig 2>

No	Name	Quantity
1	Packing case	1/1000
2	Pad	6/1000
3	Tray	1/200
4	Kraft tape	-

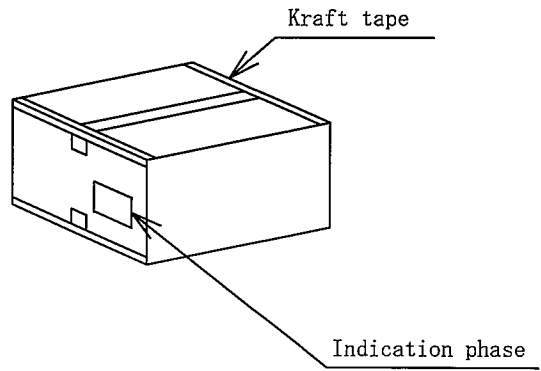

<Fig 3>

### Packing method

- 1 5 products are put in 1 pocket.  
The longer direction of the product is arranged in the arbitrary direction.  
200 products are put in the tray. <Fig.1>
- 2 The pads are attached at the top and the bottom of the trays  
and also inserted between the trays. <Fig.2>
- 3 Seal packing case with kraft tape, and stamp  
Model No., quantity, date in Indication phase. <Fig.3>  
(1000pcs./ packing case)  
(Approximately 2.26kg/ packing mass)